

Product Guide

BEO Dry Blotter

Product no. PR87

NH DyeAGNOSTICS GmbH
Weinbergweg 23
D-06120 Halle

Technical Support
Fon: +49 (0) 345-2799 6413
e-mail: service@dyeagnostics.com
www.dyeagnostics.com

copyright © NH DyeAGNOSTICS © 2017
Stand 08/2017 (1)

1 Content

- BEO Dry Blotter (blotting area: appr. 23 x 30 cm)
- 2 separation sheets

2 General Information

The most simple blotting method for handcasted, VELUM Precast or other precast gels is the contact blotting using the Beo Dry Blotter.

The BEO Dry Blotter allows for high quality blots of up to 3 large gels (27 x 20 cm) or up to 18 minigels at the same time. The protein transfer is performed by the capillary effect of water from the wet gel towards the dry blotting paper forcing the proteins to migrate onto the blotting membrane.

This simple procedure is easy to use and does not require blotting buffers or electricity. However, the quality of the blots outperforms most wet and semi-dry blots. In addition, film supported gels (e.g. VELUM Precast Gels) can be blotted without the removal of the backing.

Beo Dry Blotter is compatible with any commercially available blotting membrane.

3 Additional materials required

- transfer membrane (cut to appropriate size)
- blotting paper (5 pcs. (0.36 mm thickness) per blotting layer; cut to appropriate size)
- ddH₂O

4 Storage

Store at +15 to +30°C

5 Maintenance

Clean BEO Dry Blotter using water and/or ethanol and lintfree tissue before and after usage.

6 Protein Transfer using BEO Dry Blotter

Please also refer to the Product Guide of the Blotting Kit and the operating instructions of the transfer membrane.

6.1 Preparation

- Clean the BEO Dry Blotter (use ddH₂O and lint-free tissue).
- Equilibrate VELUM Precast Gels for 15 min in ddH₂O subsequent to electrophoresis.
- Equilibrate hand-casted gels for 10-15 min in ddH₂O subsequent to electrophoresis.
- Prepare the transfer membrane:

PVDF: wet for 15 seconds in 100% methanol and equilibrate for at least 5 min in ddH₂O.

Nitrocellulose: wet for at least 15 sec in ddH₂O.

6.2 Protein Transfer (see Figure 1a and b):

- Place the BEO Dry Blotter on plane working space and remove the cover (Fig. 1a (1)) of the BEO Dry Blotter.
- Place the equilibrated gel (for VELUM Precast Gels: with the film-support down) into the BEO Dry Blotter.
- Place the equilibrated transfer membrane on the gel. Avoid air bubbles. Once applied to the gel, do not move the membrane.

- Add blotting paper:

Wet 1 blotting paper with ddH₂O, remove excessive liquid and add to transfer membrane. Add 4 dry blotting papers on top.

Please also refer to the Product Guide of the Blotting Kit and the operating instructions of the transfer membrane.

- For a second or third blotting level use a clean separation sheet to cover the lowest blotting level and install the next blotting sandwich as before (see above).

- Place the lid on the BEO Dry Blotter.

- Fasten the lid with the nuts finger-tight.

Blotting time: 4 hours to over night
(Optimal blotting time depends on the application and has to be determined experimentally.)

- Remove the blot from the BEO Dry Blotter and rinse the transfer membrane briefly in ddH₂O.

Note: Due to the dry blotting procedure the gel will dry out and shrink after disassembly of the blot. During blotting the gel stays in place and form due to the weight of the lid. Gel shrinkage will not affect the blotting efficiency.

- Proceed with control of protein transfer (by fluorescence imaging or staining) and immuno detection or air dry the membrane for storage.

- Clean the BEO Dry Blotter (use ddH₂O and lint-free tissue).

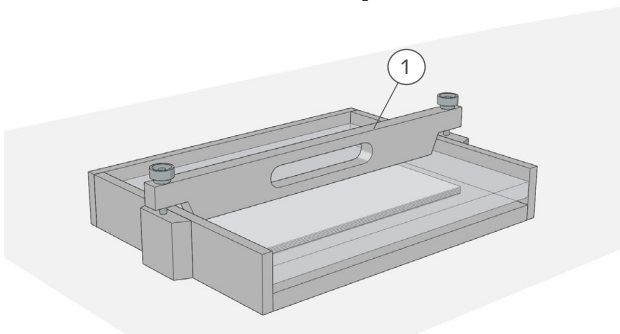

Fig. 1a. BEO Dry Blotter (1: lid)

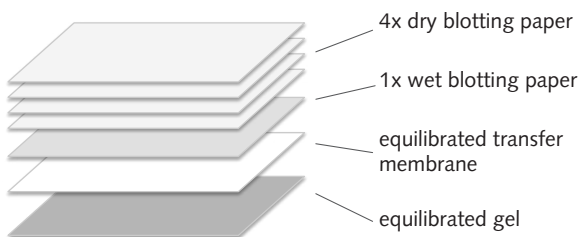

Fig. 1b. Arrangement of blotting sandwich components for BEO Dry blotting of gels